



SL Series

Friction Torque Limiters for Mining

- Single or Multi-Disc
- Hollow motor shaft mounted
- Compact design
- Custom designed for your application
- Low output inertia

PT Tech's SL series is a friction torque limiter designed for standard torque and energy requirements for mining applications. This is an economical way to protect your expensive drive train from shockload damage, while allowing your equipment to continue to perform.

No resetting is required after shockloads occur and torques are pre-set by your design staff. PT Tech has other model torque limiters for applications requiring greater torque capacity within the same diameter as the SL series.

Data sheets available upon request.



How the SL Works

The SL series friction-type torque limiters require no adjustment at installation or throughout their entire wear life. They require no lubrication and no resetting after slip has occurred. Wear can be accurately and readily measured without disturbing the unit.

SL torque limiters have five major components; input hub (Item #1), output hub (Item #2), separator plates (Item #3), a complement of spring cups (Item #4), and friction plates (Item #5). The input hub is connected to a hollow shaft electric motor using a specified spline. The spring cups create an accurate clamping force between the input hub and the friction disc pack for the life of the unit. Spring cups are color coded depending on their force. A torque setting is attained through the combinations of spring cups used. The design is a through-shaft design, where the output hub is mounted to a torque shaft. The torque shaft passes through the hollow motor shaft and is connected to the gearbox input.

A SL Series torque setting is preset at the factory. When the drive system torque exceeds the torque setting, the torque limiter will slip while continuing to transmit torque equal to the setting. This is possible because the static and dynamic coefficient of friction of the disc pack is virtually identical due to proprietary design.

The SL series torque limiter is designed to operate at motor speed. In most drive systems the prime mover represents approximately 90-95% of the equivalent inertia.

For more complete information on inertial shockloads, request PT Tech's "Torque Protection for Electric Motor Driven Equipment" brochure.

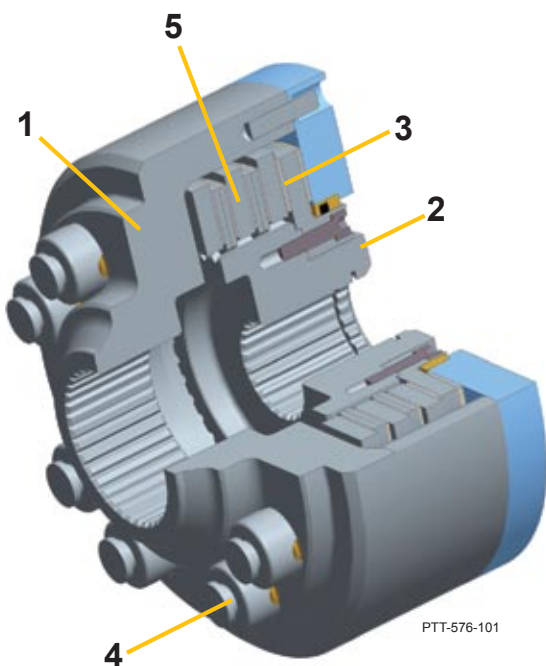



Preliminary Selection Procedure*

1) Determine Running Torque (T_R - lb-ft)

$$T_R = (\text{HP} \times 5,250) / \text{RPM}$$

2) Determine Max Torque

This information can be obtained from motor manufacturer. Typically, NEMA "B" motors have a max torque that is 250% greater than T_R

3) Determine Torque Setting (T_S)

$$T_S = \text{Max Torque} \times 1.50$$

4) Preliminary Selection Based on

- Torque setting (T_S)
- Bore requirement
- Max speed

5) Consult with PT Tech to correctly match application energy requirement and clutch energy capacity.

6) For diesel or turbine applications consult PT Tech.

* This procedure is **STRICTLY** intended as a general guideline. Consult PT Tech to finalize selection.

DIMENSIONAL DATA

SL CLUTCH SIZE		19	23	28
A Outside Diameter	inches	10	11.25	13.125
	mm	254.0	285.8	333.4
B Overall Length*	inches	6	7	5
	mm	152.4	177.8	127.0
Maximum Spline Major Diameter - Input*	inches	3.25	3.75	4
	mm	82.6	95.3	101.6
Maximum Spline Major Diameter - Output*	inches	2	2.5	3
	mm	50.8	63.5	76.2

* Numbers are approximate, subject to customer specifications.

PERFORMANCE DATA

SL CLUTCH SIZE		19	23	28
Maximum Torque	lb-ft	3312	5724	4584
	Nm	4490	7761	6215
Maximum Speed	RPM	2000	2000	2000
Inertia Total*	lb-ft ²	6.32	8.74	15.9
	kg-m ²	0.266	0.368	0.670
Inertia Output*	lb-ft ²	0.785	0.757	1.99
	kg-m ²	0.033	0.032	0.084
Weight*	lbs	74	80	105
	kg	34	36	48

* Numbers are approximate, subject to customer specifications.

Application Engineering Assistance

PT Tech has analyzed hundreds of drive systems in many types of equipment and industries. Our torque control expertise is available to our customers at no charge to help engineer possible torque protection.

PT Tech can provide a computerized report that analyzes your drive system and helps determine the need for torque protection. The computer generates a torque analysis graph comparing the maximum torque in the drive system, with and without a TLC torque limiter, under various jam conditions.

Also, PT Tech has developed a unique test stand that can simulate shockloads generated by the inertia of motors up to 2,500 HP.

Custom solutions available, contact PT Tech today.



1441 Wolf Creek Trail • P.O. Box 305
Sharon Center, OH 44274

PT Tech USA: +1 330 239 4933

sales@pttech.com • www.pttech.com

PT Tech is a subsidiary of



ISO 2001:2008
with design

* Brochure content subject to change without notice.

1/2012